

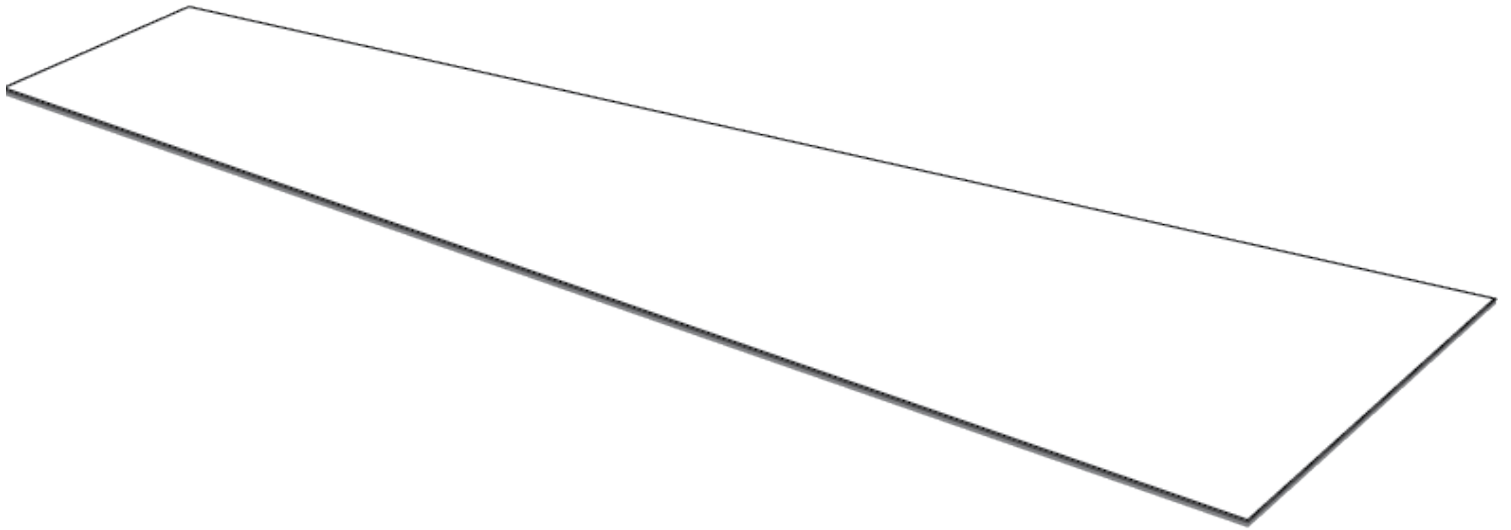

# PRO Glue Down Vinyl Flooring

KR LVT 2.5mm (0.5 wl, NF)

STYLE SELECTIONS and logo design are trademarks or registered trademarks of LF, LLC. All Rights Reserved.



## Product Guide



---

**Questions, problems, missing parts?** Before returning to your retailer, call our customer service department at 1-888-509-3438, 8:00 a.m. - 5:00 p.m., EST, Monday - Friday. You may also contact us anytime at [customerservice@novalis-intl.com](mailto:customerservice@novalis-intl.com).

## TABLE OF CONTENTS

---

Tools Needed.....	3
Important Information.....	4
Substrate Preparation.....	5
Installation Instructions.....	7
Care and Maintenance.....	10
Warranty.....	11

## TOOLS NEEDED

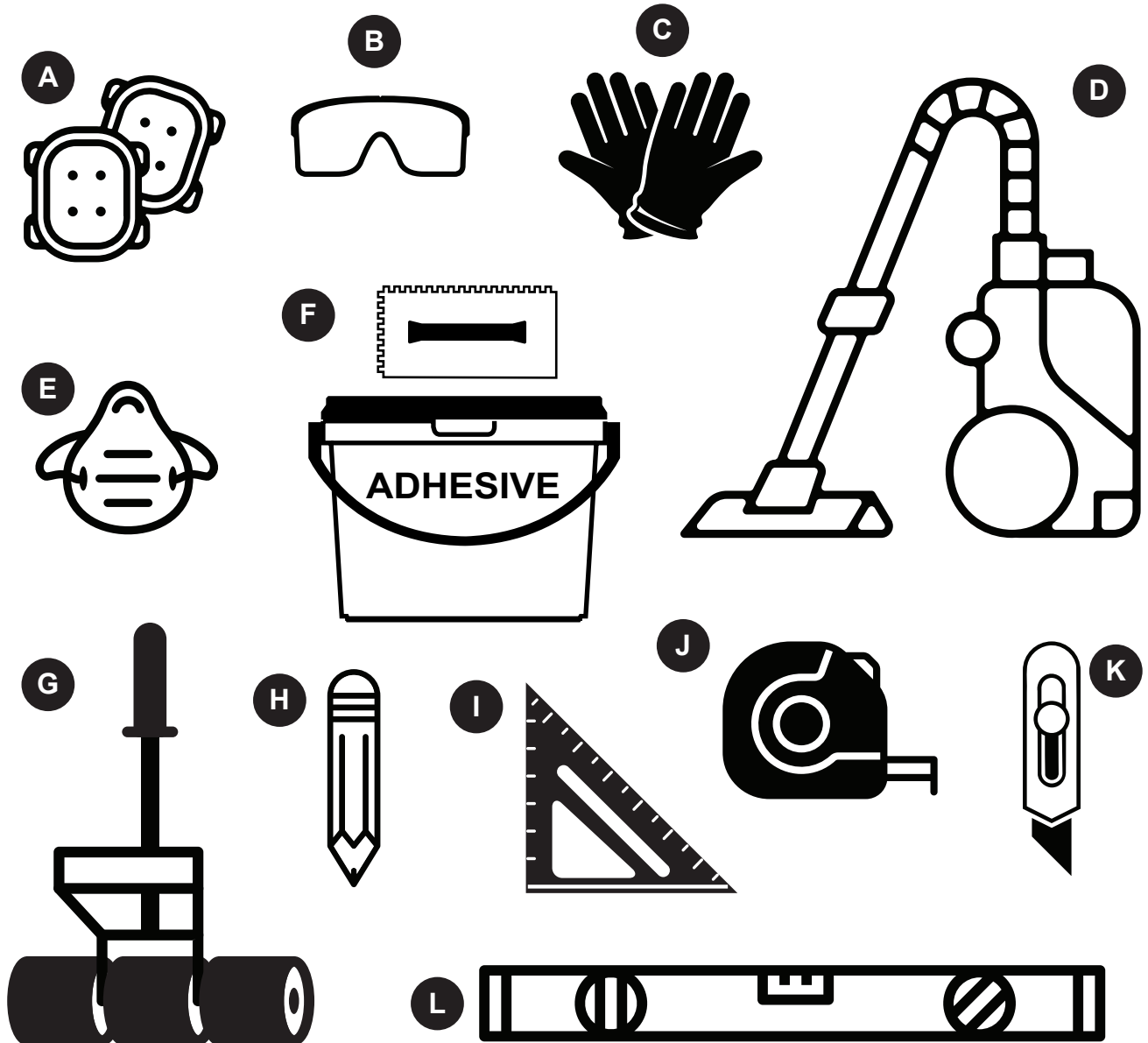

PART	DESCRIPTION
A	Knee Pads
B	Safety Glasses
C	Cut-Resistant Safety Gloves
D	HEPA-Filtered Vacuum
E	Dust Mask
F	NVGLU-1 / NVGLU-4 Adhesive & Trowel

PART	DESCRIPTION
G	Three-Section Wall Roller with Extendable Handle (~9 in. Wide) or Three-Section 100 lb. Floor Roller
H	Pencil
I	Speed Square
J	Tape Measure
K	Utility Knife with Blades
L	6-foot and 1-foot Straight Edge or Level

---

**General Information & Limitations:**

---

This flooring is a glue down vinyl product that is designed to be installed in residential or commercial indoor applications only. All installations must be performed by a qualified flooring contractor with enough general liability insurance coverage for the project. Avoid prolonged exposure to direct sunlight or other heat sources where temperatures will exceed 90° F (32° C), as damage or deformation may occur. Use non-rubber backed entrance matting at all outdoor entrances, as this will improve air quality and reduce maintenance. If required or concerned, immediately contact the technical department at 1-888-509-3438 or techsupport@novalis-intl.com for assistance.

**⚠ Warning:**

---

All local, state, and federal regulations must be followed; this includes the removal of in-place asbestos (floor covering and adhesive) and any lead-containing material. The Occupational Safety and Health Administration (OSHA) has exposure limits for people exposed to respirable crystalline silica; this requirement must be followed. Do not use solvent or citrus-based adhesive removers. When appropriate, follow the Resilient Floor Covering Institute's (RFCI) Recommended Work Practice for Removal of Existing Floor Covering and Adhesive. Always wear safety glasses and use respiratory protection or other safeguards to avoid inhaling any dust. The label, installation, and maintenance instructions along with the technical data sheet, limited warranty and any appropriate Safety Data Sheet (SDS) of all products must be read, understood, and followed before installation commences. If the substrate or subfloor fails for any reason, then the floor covering limited warranty is void.

**Site Conditions & Storage:**

---

The flooring, adhesive and accessories must be stored in dry indoors conditions between 40° F - 90° F (4° C - 32° C). Do not store outside (even in containers) and do not stack pallets. The installation area must be fully enclosed and weather tight. Protect the adhesive and tile from excessive temperature fluctuations. Use permanent or temporary HVAC systems to control the site condition. The temperature must be between 60° F to 80° F (16° C to 27° C) and constant ( ±5° F) for 48-hours before, during and after the installation. The ambient relative humidity must be between 35% and 65% and 10° F above dew point, with temperatures rising – dew point calculators are available on the Internet. Failure to ensure these conditions are met could affect adhesion and product stability.

**Documentation:**

---

Record and file the measured and observed site conditions and test results, including all photographs and corrective measures. Maintaining this documentation, along with the original invoice and any labor receipts throughout the warranty period, is recommended, as this will be required in the unlikely event of a claim.

## SUBSTRATE PREPARATION

### Flatness:

Check all substrates for flatness prior to installation. The maximum acceptable tolerance is < 1/8-in. gap (2 x US quarters) over 6-ft. and ≤ 1/16-in. gap (1 x US quarter) over 1-ft. Make any necessary adjustments to the substrate before installation. Dormant cracks, saw cut joints and grout lines < 1/8-in. wide or deep are acceptable – all others must be cleaned of all dirt and debris, then filled using a suitable commercial grade patching or repair compound, following the product instructions.

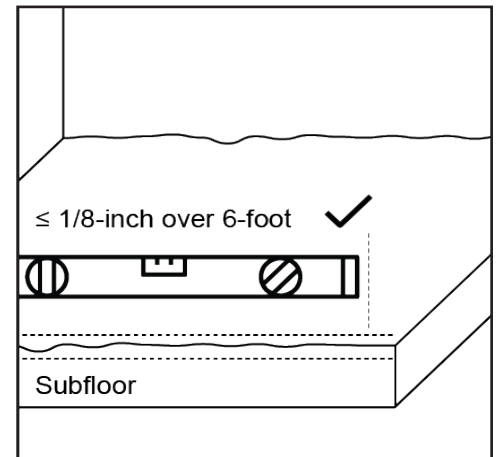

### Concrete Substrates & Concrete Moisture:

All concrete must be clean and free of contaminants. If required, using a moisture-resistant leveling or patching compound, following the product instructions. Do not install if hydrostatic pressure is visible, present or suspected. If a chemical adhesive remover has been used, contact the technical department.

All concrete slabs must be (and remain) surface dry and at least 28-days old. All on and below-grade concrete slabs must have a confirmed effective vapor retarder installed directly underneath, that meets the requirements of ASTM E1745 or use a suitable concrete moisture mitigation system. Moisture and pH tests are not usually required.

When appropriate, use a dimensionally stable surface-applied moisture mitigation system that when tested in accordance with “ASTM E96 / E96M Standard Test Methods for Water Vapor Transmission of Materials” (Method B), has a permeability value of ≤ 0.1 grains/ft.2/hour, confirm with the manufacturer before use.

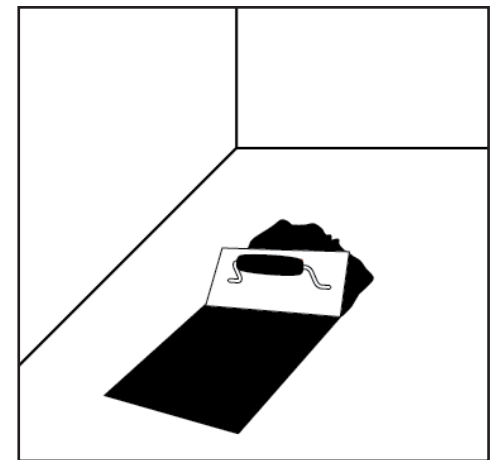

### Wood Substrates:

All wooden subfloors and substrates must be dry and in compliance with the moisture content percent (MC-%) for your region. Regional values are freely available by searching “moisture map of wood” images. Test using a non-destructive electronic moisture meter, following the product instructions. The subfloor must comply with local building codes, have at least 18-in. of well-ventilated air space below and have a suitable vapor retarder to isolate the subfloor from ground cover and outdoor conditions. Wood subfloors must have a total thickness of at least 1-in. Sleepers must not make direct contact with concrete or earth. If necessary, install an underlayment grade plywood with a minimum thickness of 1/4-in. on the surface. The underlayment must be installed in the opposite direction to the subfloor, following ASTM F1482 Standard Practice for Installation and Preparation of Panel Type Underlayments to Receive Resilient Flooring.

Note: plywood is a water-sensitive subfloor that may become damaged or deformed by topical liquids. To protect wood subfloors from topical water exposure, follow the Wet Area Guidelines.

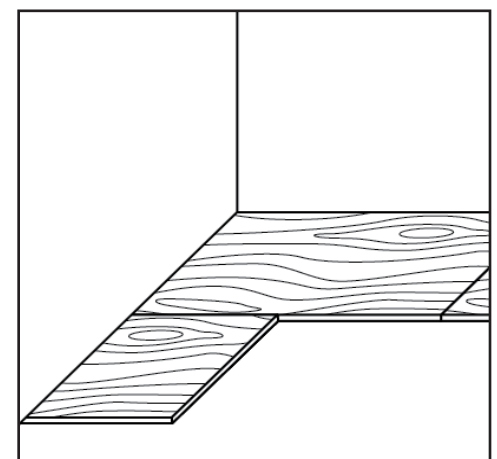

### Gypsum Substrates:

All gypsum substrates must be smooth, flat, dry, structurally sound, firmly bonded to the subfloor and free of contaminants. Refer to the primer manufacturer’s instructions regarding gypsum substrate preparation.

## SUBSTRATE PREPARATION

---

### Hard-Surface Flooring Substrates:

---

All hard-surface tile, such as ceramic, porcelain or marble tile, must be patched with a moisture-resistant leveling or patching compound, following the product instructions. All grout lines must be filled, smooth and flush with the surface of the tile, in order to prevent telegraphing and adhesion issues.

### Radiant Heating Substrates:

---

When installing floor covering over a substrate that contains a radiant heating system, ensure the radiant heat does not directly contact the floor covering and is set at the correct “in-service” temperature for 48-hours prior, during and after the installation. The radiant heat may be gradually increased or decreased to maintain the correct “in-service” site conditions.

Note: Ensure the temperature of the radiant heating system does not exceed 85°F (29°C).

### Unsuitable Substrates:

---

These include, but are not limited to: any floating or loose floor coverings, VAT, hardwood, carpet, cushion vinyl, rubber, cork, foam, asphalt tile; any substrate with visible mold, mildew, or fungi and any substrate in wet areas, such as inside showers and saunas; substrates that have been coated with a varnish or oil-based, enamel, paint, primer-sealer or stain-blocker; and substrates made of Masonite™, chipboard, wafer board, fiberboard, particleboard, construction-grade plywood, CDX, OSB (including AdvanTech™), Lauan, cement board or any non-underlayment grade panels must be removed and replaced or covered with an underlayment grade plywood. Do not use pressure-treated or fire-retardant plywood. Do not install directly over adhesive residue. Do not install in recreation vehicles, campers or boats.

### Other Subfloors/Substrates:

---

Installing over existing resilient vinyl flooring is not recommended. However, it may be possible over some materials, such as hardwood flooring, VCT, quartz tile, solid vinyl tile, sheet vinyl or linoleum. Ensure existing flooring is a single layer and is clean, dry, sound, solid and well adhered. All loose material must be removed and repaired or replaced. All grout lines and wide seams greater than 1/4-in. in width and/or depth, as well as any significant substrate imperfections, must be filled and troweled flush with a suitable cementitious patch.

Note: Existing hardwood floor coverings will swell when exposed to moisture - vinyl floor covering may restrict the movement of moisture in hardwood, which may result in flooring failure, especially when installed on or below grade. Some hardwood floor coverings may also discolor vinyl floor covering, which is excluded from warranty coverage. Electing to install over any existing floor covering releases the manufacturer from any responsibility regarding the suitability and continued performance of the product, including any resulting effect on the new floor covering.

# INSTALLATION INSTRUCTIONS

## Acclimation:

Depending on the temperature of the floor covering, an extended acclimation period may be required. Check the temperature of the floor covering using a non-contact, infrared thermometer - the floor covering must be at the same temperature as the required site conditions ( $\pm 2^{\circ}$  F) before installation.

## Layout:

Determine the ideal installation pattern and direction. Measure the width of each end of the area, then calculate and mark your starting line with a pencil, which should be near the center of the room. Calculate the width of the last row – if it is less than half the width of the floor covering, adjust your starting line by half the width of the flooring. Make sure all pencil markings are bold and clear - do not use a pen or permanent marker. It is recommended that plank end joints be staggered randomly by at least 8 in. to avoid an undesirable “stair stepped” or “H joint” pattern. Tiles are recommended to be installed either in a brick-bond or a 1/3rd off-set pattern.

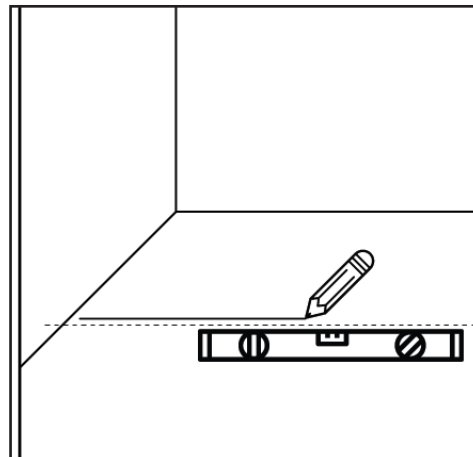

## Cleaning:

Clean the substrate using a HEPA filtered vacuum. If a significant amount of time has lapsed since initial cleaning, clean the substrate directly before flooring installation using a HEPA filtered vacuum.

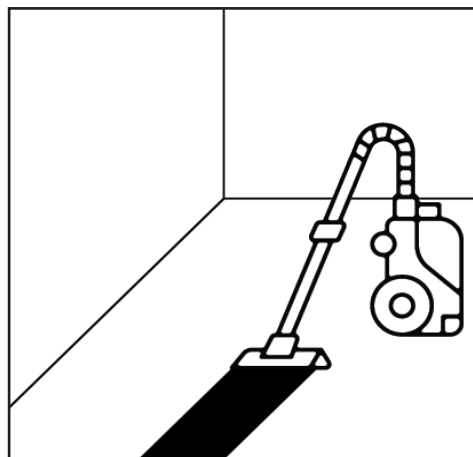

## Grouting:

If the product has a micro-beveled edge, the flooring may be grouted. During installation, leave a consistent gap around all four sides of the tile or plank – the gap should be created using appropriate tile spacers and should be 1/16-in., 1/8-in. or 3/16-in. wide. Remove the spacers just before rolling and grout the joints using a flexible grout specifically made for vinyl floor covering. Follow the product instructions regarding its application and cleaning.

Note: Any grout residue left on the surface will affect product maintenance and is not covered under the warranty.

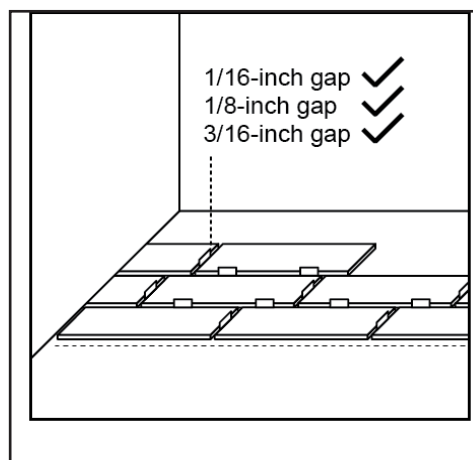

# INSTALLATION INSTRUCTIONS

## Cutting:

To cut the floor covering, measure and mark the surface with a pencil, then carefully score the surface a few times using a sharp utility knife along the side of a speed square. Snap the piece downwards to complete cut.

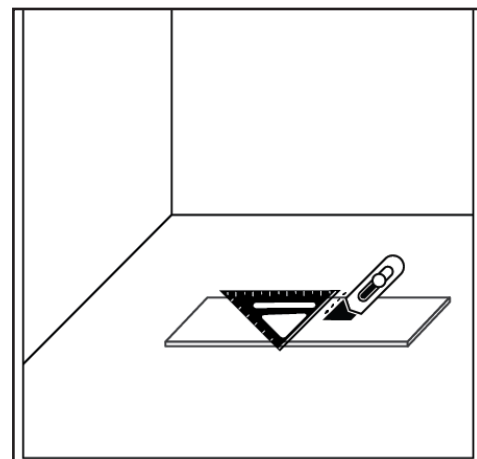

## Adhesive Application:

Coverage for the NVGLU-1 / NVGLU-4 adhesive is 125 - 250 sq. ft. per gallon, depending upon the substrate and trowel angle. Adhesive is available in 1-gallon or 4-gallon units from [Lowes.com](https://www.lowes.com). Replace trowels every 4 gallons to ensure even coverage - do not re-notch trowels.

Only apply as much adhesive as can be covered within the working-time (4-hours). Apply the adhesive slowly and evenly to the substrate at a ~45° angle using the specified trowel notch. Avoid skips, puddles or sharp trowel turns. Allow 15-30 minutes of open time for the adhesive, depending on conditions. The adhesive should be dry to the touch - do not install the flooring into wet adhesive.

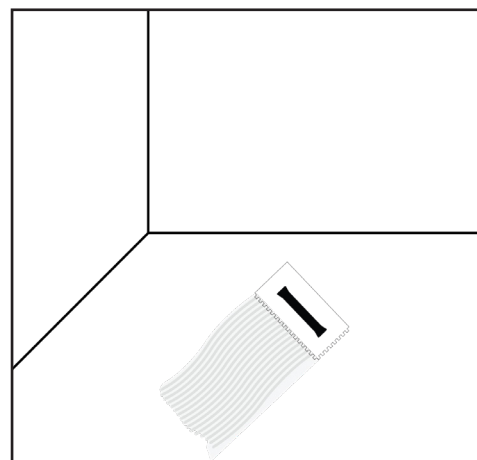

## Flooring Installation:

Mix floor covering from several boxes to ensure a consistently random appearance. During the installation, inspect each piece for visible defects, including damage, gloss, color, or shade variations. Do not install any floor covering with visible defects or damage, as removal, subfloor repair and replacement labor costs will not be covered.

Follow the layout and starting line and carefully position each piece accordingly, keeping all joints snug without compressing the material. Check to ensure the starting row is straight - the acceptable straightness tolerance is within 1/16-in. for lengths over 20-ft. or 1/32 in. for lengths under 20-ft.

After the first installation section is completed, roll the entire area slowly, across the width then length, using a using a wall/laminating three-section roller with extendable handle and your body weight or a 100 lb. three-section roller. Failure to roll correctly may result in bond failure. Repeat this process for the remainder of the installation.

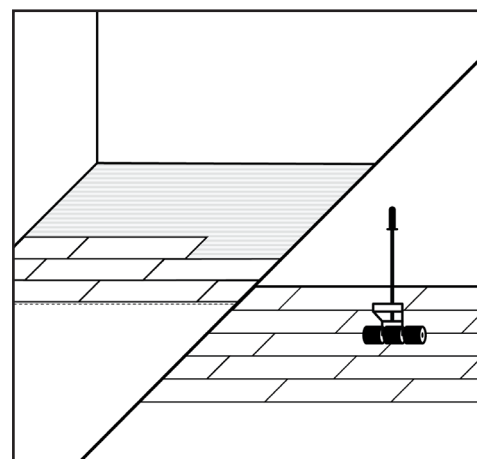

Immediately remove all adhesive from the surface using a clean damp cloth. If the adhesive has dried, use a small amount of 70% Isopropyl alcohol and a clean cloth to remove it.

## Completion:

Save three or more extra pieces of material in the original packaging as attic stock for the lifetime of the floor. **In the unlikely event of a product issue, attic stock can play a crucial role in product identification, color matching, product claim verification and possible repairs.**



---

**Protection:**

---

For furniture, use only polyurethane, silicon or felt glides (replaced > 3-times a year), keeping them clean and grit-free – all glides should be  $\geq 1\text{-in.}^2$ , especially on heavy furniture. Use chair mats underneath rolling chairs or soft “W-type” wheels. Use non-rubber-backed entrance matting at all outdoor entrances, as this will improve air quality and reduce maintenance. Do not drag heavy or sharp objects directly across the surface - use hard surface “sliders” (available at Lowe's). For areas that may be subjected to standing water on the surface, such as bathrooms with a bath or shower, the perimeter of the installation must be properly sealed using a 100% silicon caulk to prevent water from getting beneath the flooring. To avoid excessive fading or discoloration from direct sunlight exposure, use appropriate window treatments.

## CARE & MAINTENANCE

---

### **⚠ Precautions:**

---

Remove all metal objects before conducting maintenance and prohibit foot traffic until the floor is dry. Do not use dust mops treated with oils or silicones, acetone, strong alkaline cleaning agents, multi-surface cleaners, vinegar/ ammonia/ citrus oil solutions, scouring powder, strong solvents, or abrasive cleaning pads, as these can damage the flooring. Do not wet mop or allow cleaning solutions to puddle or pool on the surface of the material. The application of a floor-finish is not recommended and will change the maintenance protocol.

### **Regular Cleaning:**

---

Dust-mop or vacuum the floor to remove any dirt or grit – do not use a vacuum with a beater bar. Damp-mop the floor as often as required using a flat microfiber mop or a spray mop or a flat microfiber spray mop. We recommend a pH neutral, film-free and streak-free cleaner concentrate (diluted with potable water), available at Lowe's. Make sure to change the mop pad as often as required.

# LIMITED WARRANTY

## 1. General Terms:

Novalis Innovative Flooring (“Manufacturer”) warrants that, when used properly and under normal operating conditions, the flooring products described in the Manufacturer’s catalog as Style Selections PRO Luxury Vinyl Tile (“Product”), a glue down vinyl floor covering. The Product is a Luxury Vinyl floor covering (LVT/LVP) that is adhered using an approved adhesive. The Product will conform to the published Product technical documents. All installation outside of these parameters shall void this Limited Warranty.

This Limited Warranty is not transferable and only applies to the original end-user (“Customer”) of the Product. This Limited Warranty does not apply to Product that has been sold or resold as “seconds”, “mill-run”, “off goods”, “non-conforming”, “as-is”, “closeouts” or otherwise denoted as irregular, non-first or non-standard quality.

The Manufacturer’s liability and Customer’s exclusive remedy under this Limited Warranty is limited to the replacement or refund of the defective Product and, only if without visible and obvious (> 0.5-inch) defects will the Manufacturer include reasonable labor costs for the geographic region. This Limited Warranty does not include other costs associated with installation or removal of the defective Product or installation of the replacement Product including, but not limited to, lost time, furniture removal and/or overtime pay. Only one replacement floor or refund shall be made. A Customer who received a settlement may not make another claim - no additional replacement floors or refund will be supplied.

If the Manufacturer no longer provides the particular Product subject to this Limited Warranty, Manufacturer reserves the right to substitute another Product that Manufacturer deems to be comparable or superior in its place. Manufacturer’s responsibility to replace defective Product under this Limited Warranty applies only to the affected area of Product so long as a suitable match (as determined and at the sole discretion of Manufacturer) can be supplied. Full replacement or replacement of a greater area than the affected area is at the sole discretion of Manufacturer. Manufacturer reserves the right to provide replacement materials directly to the Customer, or through a professional installation company of the Manufacturer’s choice, to conduct repairs or replace materials in a manner suitable to the Manufacturer’s interests.

This Limited Warranty is specific to the Product which shall be installed, used, maintained and cared for in accordance with the Product documentation, which may be obtained at [www.lowes.com](http://www.lowes.com) or are available upon request by contacting [techsupport@novalis-intl.com](mailto:techsupport@novalis-intl.com) or 1-888-509-3438.

## 2. Warranty Terms & Provisions:

**2.1. Manufacturing Defect Term:** The Product shall be free of manufacturing defects for a period of 1-year from the Customer date of purchase. All claims must be reported within thirty (30) days of discovery of the defect.

**2.2. Wear Warranty Term:** “The Product”, when installed and maintained as detailed within the instructions, will not wear-through to the printed film layer under normal use for the period stated below:

<b>Residential Wear:</b>	Lifetime from date of purchase
<b>Light Commercial Wear:</b>	10 years from date of purchase

**2.3. Wear Warranty Provisions:** Designated areas are as follows:

<b>Specialty Retail</b>	Art galleries, jewelry stores, boutiques / clothing stores, gift shops
<b>Medical</b>	Doctor offices & waiting rooms, exam rooms, reception areas (Hill-Rom type beds excluded)
<b>Multi-Use</b>	Living spaces/apartments/hotel rooms, laundry rooms, storage areas, conference rooms, light-use exercise rooms (no free weights or aerobics, must use heavy vinyl mats under equipment)
<b>School / Institution</b>	Meeting & training rooms, offices, common areas, lobbies, storage areas, reception areas
<b>Office / Industrial</b>	Offices, reception areas, storage rooms, conference & training rooms

Stains from unapproved chemicals, fading, scratches, scuffs, and loss of gloss are considered normal use and are not covered under this warranty. The Manufacturer will supply new material of the same color, design, and grade, if available; if unavailable or discontinued, the Manufacturer reserves the right to supply similar floor covering. After corrective action is taken on an existing defect, Limited Warranty coverage will remain in effect for the remaining Wear Warranty Term of the original Limited Warranty.

Alternatively, at the Manufacturer’s discretion, a refund of the original cost of the Product shall be used to settle all other valid claims according to the following pro-rated schedule:

Residential Wear Coverage:	Light Commercial Wear Coverage:
≤ 2 years: 100%	≤ 1-years: 100%
≤ 6 years: 70%	≤ 3-years: 70%
≤ 12 years: 50%	≤ 5-years: 50%
≤ 20 Years 30%	≤ 7-years: 30%
> 20 years: 10%	≤ 10-years: 10%

**2.4. Labor Warranty Term & Provisions:** Labor costs shall not be reimbursed for all material installed with visible and obvious (> 0.5-inch) defects. Reasonable costs of professional labor for replacement must be submitted to and pre-approved by the Manufacturer. The percentage of labor costs that shall be reimbursed is according to the following pro-rated schedule:

Residential Labor Coverage:	Light Commercial Labor Coverage:
≤ 1-year: 100%	≤ 1-years: 100%
≤ 5-years: 60%	≤ 3-years: 60%
≤ 10-years: 40%	≤ 5-years: 40%
≤ 20-years: 20%	≤ 7-years: 20%
> 20-years: 0%	> 7-years: 0%

**2.5. Waterproof Warranty:** The Product is waterproof in accordance with the Resilient Floor Covering Institute's White Paper on Waterproof Flooring and will not be materially impaired when exposed to wet or damp cleaning, surface spills and/or tracked in water for the length of the Wear Warranty. This does not include bathing and/or showering kits, units or areas, saunas, steam rooms, or water emergencies.

**2.6. Petproof Warranty:** The Product surface coating provides scratch and stain resistance (such as feces, urine and/or vomit) from domestic household pets, such as cats and dogs, provided that pet claws are routinely cut and filed.

### 3. Warranty Exclusion:

This Limited Warranty does not apply to nor cover nonconformities that are caused by, result from or arise in connection with any of the following conditions:

- **Non-Compliance with applicable Product requirements and technical data.** Any Product that has been subjected to site conditions, substrate conditions, installation methods, maintenance procedures and/or conditions of use that are not in strict conformity with the associated Technical Data Sheets, Installation Instructions, Maintenance Documents and any other relevant technical documents.
- **Non-Compliance with applicable industry guidelines.** Substrate preparation must be performed in accordance with all related ACI, ASTM, NWFA and RFCI guidelines.
- Installation of Product with any third-party adhesive not explicitly recommended or approved by Novalis Innovative Flooring. The use of unapproved adhesives excludes any warranty coverage of adhesive performance is-sues, including but not limited to bond strength, shrinkage, expansion, peaking, ledging, curling, doming and/or the ability of the adhesive to control the dimensional stability of the floor covering. This also excludes any associated material and labor costs associated with third-party adhesives.
- Installation of Product with unapproved installation materials, methods or tools, including but not limited to the recommended underlayment type, repair products and all accessories.
- Cracking, warping, delamination, curling, or other phenomena caused by excessive heat sources, such as prolonged direct sunlight, radiators, self-cleaning ovens and high-heat equipment.
- Fading or discoloration of the surface due to excessive UV/IR exposure.
- Stains from tracked carpet dyes, fertilizers, coal, tar, driveway sealers, oil, permanent markers, or other such contaminates.
- Substrate failure, movement or imperfections, including improper flatness, smoothness or damage.
- Hazing or finish-related issues caused by the grout and or residue when used with the Product.
- Heavy static loads (>1,500 lbs.) and heavy point loads, such as foot traffic with stiletto heels, spikes or skates, dropped items, improper floor protectors and furniture feet/rests or floor protection and furniture feet/rests that do not make adequate flat contact with the floor covering.
- Heavy rolling loads (> 1,500 PSI) with metal wheels, hard H-type wheels or any other wheel types that do not make adequate, flat contact with the floor covering.
- Damage caused by mechanical issues, intentional abuse, misuse, negligence, structural damage, seismic activity,

flooding, fires, and other emergencies, natural disasters or any circumstances beyond the reasonable control of the Seller.

- Damage or excessive wear caused by improper maintenance dirt, grit, and abrasive debris from not using appropriate walk-off mats at all outdoor entrances.
- Any resulting health issues or property damage resulting from organic growth resulting from any type of water trapped beneath the floor covering and the latent organic material found within it, which may sponsor organic growth, such as mold, mildew, and fungi.
- Normal shade, color, gloss/sheen, or embossing texture variation, including variations between installed flooring and physical flooring samples or printed marketing materials.
- Excessive moisture and alkalinity from the subfloor or substrate.
- Excessive topical water caused by broken or leaking plumbing, structural leaks, sink overflow, flooding, weather conditions and other water emergencies.
- Installations removed or replaced prior to inspection by an authorized Novalis representative.

#### **4. Slip Resistance Warning:**

---

Walking is an enormously complex activity involving many muscles, bones and nerves, as well as kinesthetic sensory information. There are several significant factors that directly affect slip resistance properties, such as the type, texture and surface structure of floor covering, surface contaminants, type of shoe soles and the walker's weight, age, gait, fitness level, awareness, and vision. There are no published requirements or acceptable limits for Static Coefficient of Friction (SCOF) or Dynamic Coefficient of Friction (DCOF) values within the resilient flooring industry, though there may be for other flooring types. While independent test results are available, that does not purport to address any safety concerns of slip resistance, the accuracy of all test methods, safety thresholds, or the measuring apparatus' (tribometers). This includes factors outside of the reasonable control of the Manufacturer, such as Product maintenance. No warranty for any slip resistance properties can be provided.

Note: Walking on any vinyl floor covering in socks or similar is not recommended, especially on stairs.

#### **5. Warranty Claims:**

---

If, within the applicable warranty period identified in Article 2.1 and 2.2, the Customer discovers any problems or defects in the Product that may be covered by this Limited Warranty, the Customer must notify the distributor or the Manufacturer directly at 1-888-509-3438 (option 2) or [claims@novalis-intl.com](mailto:claims@novalis-intl.com). All claims must be reported within thirty (30) days of discovery of the problem or defect.

All claims must include a completed claim form, along with any associated photos, invoices, pre-installation testing reports and all independent inspection reports conducted after problems or defects are observed or suspected. Attic stock may be required to verify the validity of product claims. Failure to provide attic stock could lead to product claims being declined, especially in the event that third-party products, such as but not limited to adhesives, accessories and underlayments, are used in conjunction with The Product.

If Manufacturer determines that the Product is covered by this Limited Warranty, then Manufacturer shall, at its sole option, replace the nonconforming Product or refund the appropriate percentage of the purchase price and labor cost paid for each defective Product for the affected area, per the associated pro-rated schedule. No warranty claims will be processed if received more than thirty (30) days after the applicable warranty period has ended.

Manufacturer or its designated representative shall have the right to examine the Product and the flooring, including the right to test the flooring and/or substrate at the installation site, with respect to any Product that is the subject of a warranty claim. Any removal of installed Product prior to such examination will void any and all warranties. Manufacturer may require additional testing or verification of any tests conducted or obtained by the Customer.

#### **6. Warranty Disclaimer:**

---

The warranties set forth herein are exclusive and in lieu of all other warranties or representations, express or implied, arising by law or custom, including the implied warranties of merchantability and fitness for a particular purpose. No agent, sales representative, dealer, distributor, contractor, installer, architect or designer has the authority to increase or alter seller's obligations under this warranty. This Limited Warranty does give you specific legal rights; you may also have other rights, which may vary from state to state.

#### **7. Limitation of Liability:**

---

The aggregate cumulative total liability of Manufacturer hereunder, whether for breach of warranty or contract, indemnification, tort (including negligence), or otherwise, shall not exceed the original purchase price of the nonconforming Product. Manufacturer assumes no liability for labor costs in the installation or replacement of

---

any Product with visible and obvious (> 0.5-inch) defects. In no event shall Manufacturer be liable to Customer or any other person for loss of revenue, profit or any consequential, incidental, exemplary or punitive damages directly or indirectly arising from the use of the Product, from breach of any warranty or from any other cause, whether or not Manufacturer has been informed of the possibility of such damages.